

# LineLED 24V - Installation Instructions

## Models LL9-, LL18-, LL30-, LL36-

**Please read all instructions prior to installation and keep for future reference!**

T 224.333.6033

www.opticarts.com

1. Product should be installed by a qualified electrician.
2. Prior to installation ensure power is off at fuse box to prevent electrical shock.
3. Use only with Class 2 power unit. *Utiliser seulement avec Classe 2 unite d'alimentation electrique.*
4. Suitable for Damp Locations. *Convient Aux Emplacements Humides.*
5. For under-cabinet or shelf mount.
6. Conforms to UL STD 2108. Certified to CSA STD C22.2 No.250.0.



Page 1 of 2

**Attention:** Always test LineLED operation before installing.  
Connect LineLED to power supply to ensure it is working properly and no damage has occurred during shipping.

**1** Clean the area thoroughly where the LineLED will be installed.

Remove the paper backing from the LineLED and firmly press down making sure there are no air bubbles that can cause surface irregularities. **Do not remove the adhesive, removing the adhesive may cause arcing of the Line LED tape.**

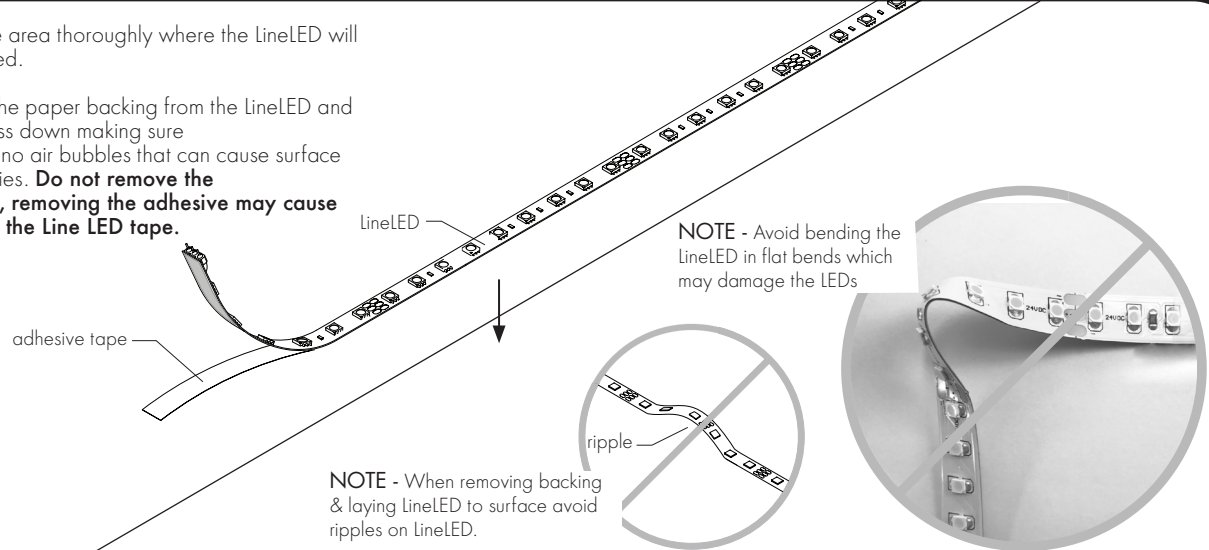

**2**

**NOTE - Plus-sign label on power feed wire cable indicates positive polarity. Non-marked wire cable indicates negative polarity.**

LineLED power feed can be trimmed to length as needed

If LineLED power feed is done with 72" wire leads, proceed to wiring with power supply. Otherwise, connect the LineLED power feed connector to the LineLED strip by sliding and securing end of LineLED power feed to male or female connector. **Secure by placing clip (one is provided) over the connector and secure using the two screws. Shown below**

**NOTE - Provided 3-pin connector in the LineLED power feed can be removed to allow connection to female end of LineLED. See second illustration below.**

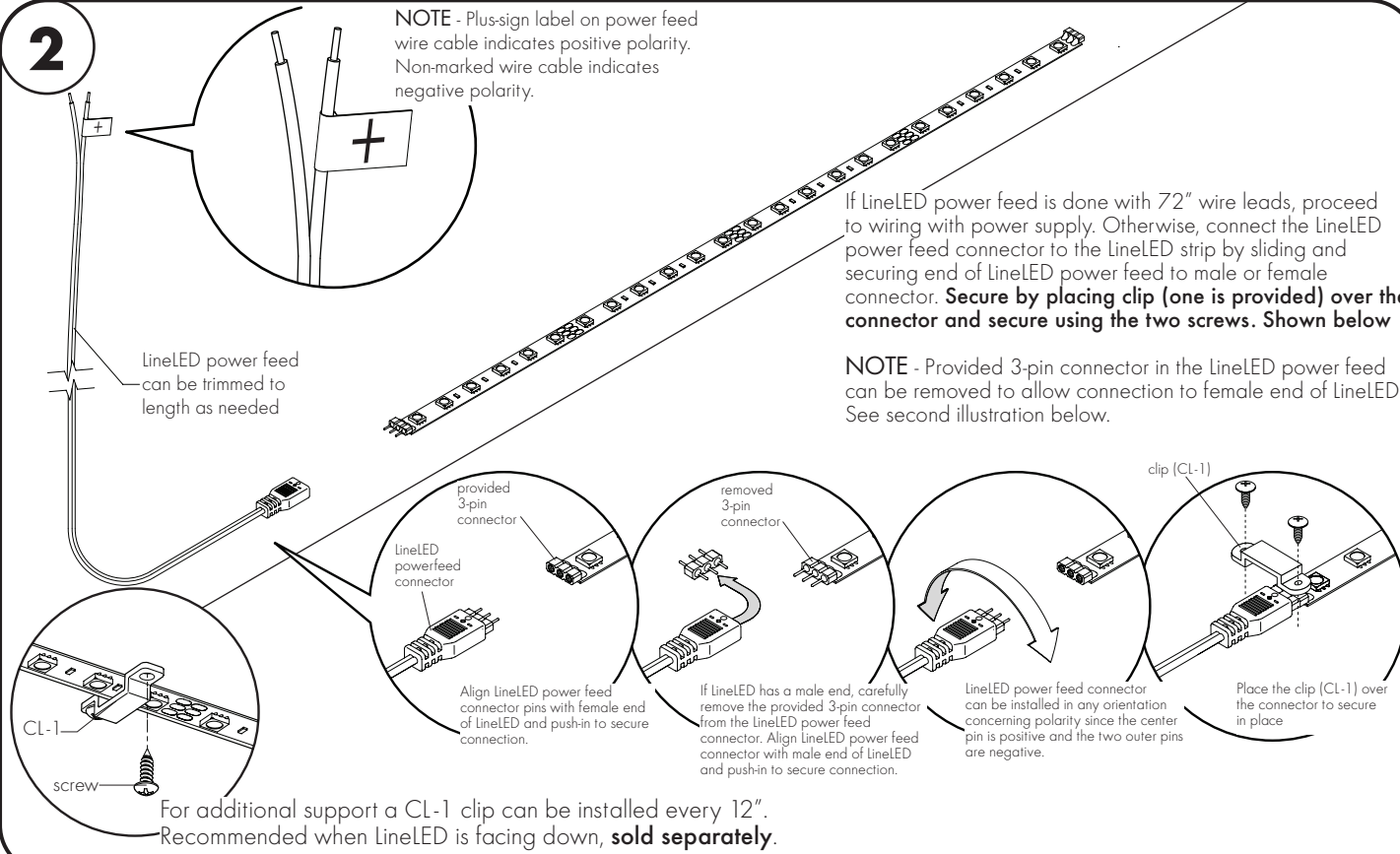

Align LineLED power feed connector pins with female end of LineLED and push-in to secure connection.

If LineLED has a male end, carefully remove the provided 3-pin connector from the LineLED power feed connector. Align LineLED power feed connector with male end of LineLED and push-in to secure connection.

LineLED power feed connector can be installed in any orientation concerning polarity since the center pin is positive and the two outer pins are negative.

Place the clip (CL-1) over the connector to secure in place.

For additional support a CL-1 clip can be installed every 12". Recommended when LineLED is facing down, **sold separately.**

# LineLED 24V - Installation Instructions

## Models LL9-, LL18-, LL30-, LL36-

**Please read all instructions prior to installation and keep for future reference!**

T 224.333.6033

www.opticarts.com

1. Product should be installed by a qualified electrician.
2. Prior to installation ensure power is off at fuse box to prevent electrical shock.
3. Use only with Class 2 power unit. *Utiliser seulement avec Classe 2 unite d'alimentation electrique.*
4. Suitable for Damp Locations. *Convient Aux Emplacements Humides.*
5. For under-cabinet or shelf mount.
6. Conforms to UL STD 2108. Certified to CSA STD C22.2 No.250.0.



Page 2 of 2

### 3

If length of LineLED needs to be adjusted on site, simply cut the LED strip in between solder pads. Always cut from end with no connector/wire leads. Then use field-cut connectors to power or extend cut sections of LineLED.

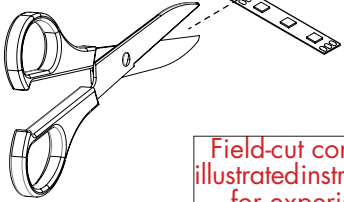

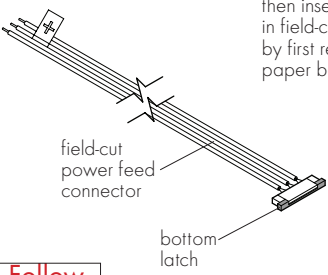

field-cut power feed connector  
bottom latch

Field-cut connectors are delicate. Follow illustrated instructions carefully. Recommended for experienced LED installers ONLY.

#### STEP A

pull out field-cut connector bottom latch so it can accommodate the LineLED strip

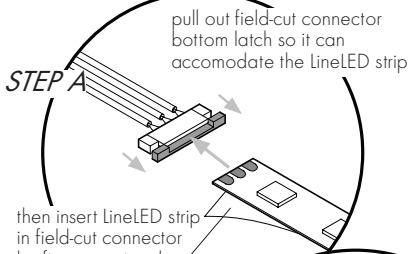

then insert LineLED strip in field-cut connector by first removing the paper backing

#### STEP B

after LineLED is inserted completely in the connector, push bottom latch in - applying equal pressure on both sides

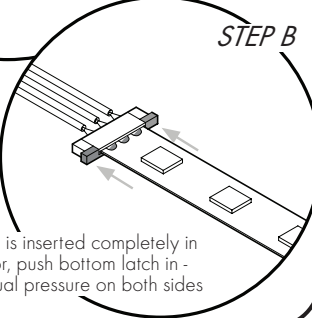

### 4

#### RECOMMENDED LAYOUT FOR MULTIPLE ADJACENT RUNS OF LINELED FED WITH SEPARATE POWER SUPPLIES

Position power supplies either in the middle of two runs or at the opposite ends.

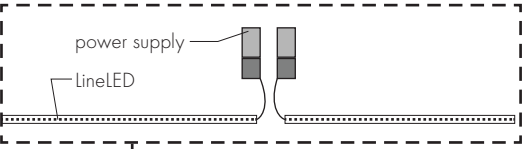

power supplies placed in the middle of two adjacent runs

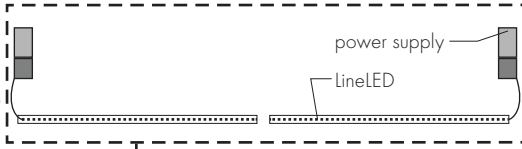

power supplies placed at the opposite ends of two adjacent runs

### 5

**Always ensure power to power supply is off!** Follow diagrams to connect power feed wires to power supply. Refer to power supply instructions for wiring line voltage side.

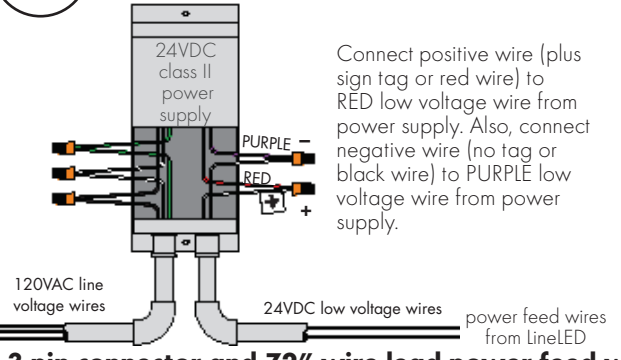

Connect positive wire (plus sign tag or red wire) to RED low voltage wire from power supply. Also, connect negative wire (no tag or black wire) to PURPLE low voltage wire from power supply.

**3-pin connector and 72" wire lead power feed wiring**

OR

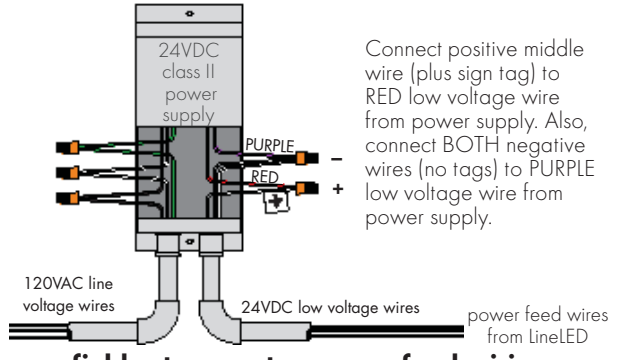

Connect positive middle wire (plus sign tag) to RED low voltage wire from power supply. Also, connect BOTH negative wires (no tags) to PURPLE low voltage wire from power supply.

**field-cut connector power feed wiring**